

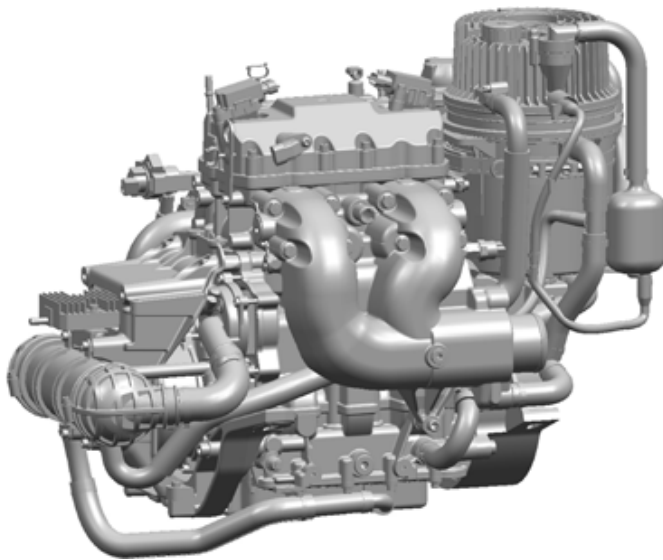

## MPE 750 NA Marine - Closed Loop

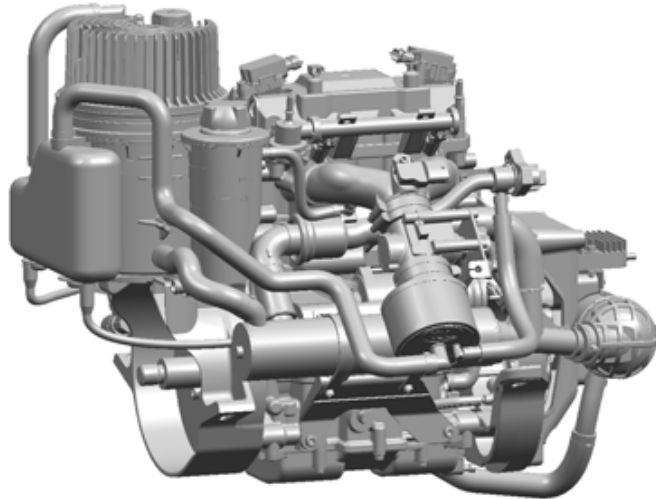

This service manual is valid for the following engine variants:

- 402062\_I2 749 MAR NA-66 DS V1 2007 1.1



## Table of contents

1	About this document	1
1.1	Meaning of the symbols in the text	1
2	Safety	2
2.1	Basic principle	2
2.2	Meaning of the safety symbols	2
2.3	General safety instructions	3
3	Description	4
3.1	Technical specifications	4
3.2	Serial number	4
3.3	Operating materials	5
3.4	Running in the engine	7
3.5	Operating the engine without sea water	7
4	Maintenance	8
4.1	Maintenance work by the user of the vehicle	9
4.2	Maintenance intervals	10
4.3	Decommissioning at the end of the season	11
4.4	Motor oil and oil filter	12
4.5	Engine cooling circuit	18
4.6	Spark plugs	22
4.7	Valve play	25
5	Malfunctions	31
6	Terminology	34
7	Appendix	35
7.1	Directives	35
7.2	Exhaust type authorizations	36
8	Proof of maintenance for work carried out	37







## 1 About this document

This chapter will familiarize you with the structure of this document so that you can find the information it contains quickly and easily.

This document uses symbols and signs that allow you to find information quickly. Please read the explanations of the symbols and signs in this chapter. Be sure to read all safety instructions in this service manual especially carefully.

Always keep this documentation handy and make sure it is always in the vehicle. Be sure to inform other users of all safety provisions.

### 1.1 Meaning of the symbols in the text

Symbol / Sign	Use	Explanation
	Need	Required tools for carrying out the activities in this section.
	Need	Required spare parts for the activities in this section.
	Information	Information about assembly, e.g. tightening torques.
	Information	Note about required lubrication.
[ ]	Information	Alternative measurement units are in square brackets.
	Information	This sign indicates recommendations and particularities.
1.	Instruction	Here you must do something.
2.		Instructions must be carried out in the sequence specified. Deviations from the specified sequence can cause damage to the engine and accidents.
...		
–	Instruction. List.	Here you must do something. Enumeration.
See ...	Cross-reference	References to other chapters and figures.



## **2 Safety**

### **2.1 Basic principle**

This engine is state-of-the-art and built according to recognized safety-technical regulations. Nevertheless, people can be injured or the engine damaged if the safety instructions in this manual are disregarded.

Only put the engine into operation if it is technically perfect. Faults that compromise the safety of people or of the engine must be eliminated immediately by trained service personnel.

Arbitrary constructional changes to the engine are not permitted and void the warranty.

In addition to this documentation, heed generally-valid legal and other binding regulations for accident prevention and environmental protection. Such duties can affect the handling of hazardous materials or the provision and wearing of personal safety equipment or traffic regulations, for example.

### **2.2 Meaning of the safety symbols**



Disregarding this sign can endanger life and limb.



Disregarding this sign can cause injuries to persons.



Disregarding this sign can cause damage to the engine.



## 2.3 General safety instructions



### ATTENTION

The engine may only be operated at idle speed for a maximum of 30 seconds without sea water. Engine damage due to overheating.

See Chapter **Operating the engine without sea water**.



### ATTENTION

Lift a **submerged engine** out of the water as quickly as possible and take it to a professional shop for maintenance within 24 hours. Belated measures can cause severe damage to the engine.

### 3 Description

The MPE 750 Marine - Closed Loop is a 2-cylinder in-line engine. It is intended for recreational watercraft. It is not designed for constant loads at high speeds as can occur during races, for example.

#### 3.1 Technical specifications

Type	2-cylinder parallel twin with vibration compensation shaft
Displacement	749 cm <sup>3</sup>
Engine power	49 kW (66 PS) [66 HP] ISO 8178 7500 U/min [RPM]
Max. speed	8000 U/min [RPM]
Combustion system	Intake-manifold fuel injection
Injection regulation	electronic
Lubrication system	Dry sump
Cooling system	Water-cooled with closed coolant circuit and open sea water cooling circuit

#### 3.2 Serial number

The 8-digit serial number (1) serves to identify the engine. It is engraved in the motor housing (2) and glued on as a label (3). Using this number, it is possible to determine the production date and all parts built into the engine.

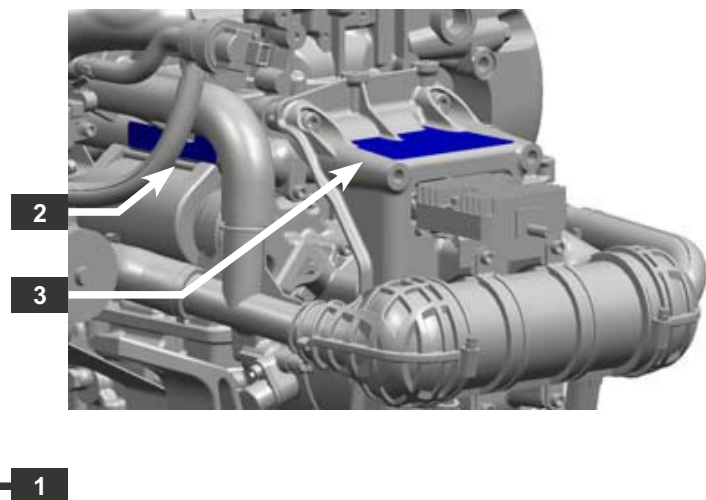
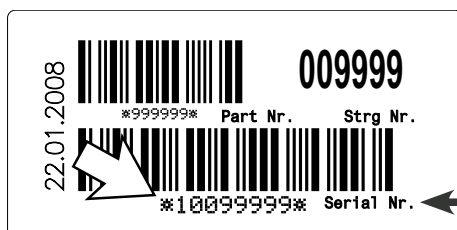



### 3.3 Operating materials



#### ATTENTION

The use of other operating materials causes damage to the engine and the voiding of the warranty.

#### Fuel

Fuel quality

Unleaded gasoline according to DIN 51607 („super unleaded“), with an octane rating of at least 95 ROZ [RON] or 85 MOZ [MON].

In case of emergency, unleaded fuel with 91 ROZ [RON] or 82.5 MOZ [MON] may be used for a short time.



#### ATTENTION

Lower-quality fuels should only be used in case of emergency. If used regularly, they cause decreases in performance and possibly damage to the engine.

#### Lubricant

Oil specification

Recommendation: 15W 50 completely synthetic, API SH, JASO MA  
Alternative: 0W 50  
Minimum requirement: 0W 40

Fill quantity

Initial filling 4.2 liters [4.4 qt (US)]  
Oil change with filter 3.3 - 3.5 liters [3.5 - 3.7 qt (US)]



## Coolant

Coolant additive	Coolant additive based on ethylene glycol Silicate- and nitrite-free. Suitable for aluminium engines.
Anti-freeze mixture	50 % water + 50 % coolant additive Manufacturer's fill provides frost protection up to -37 °C [-34.6 °F] Recommended minimum frost protection up to -30 °C [-22 °F]
Fill quantity	3,3 liters [3.5 qt (US)]
Approved coolant additives	BASF Glysantin G 30 Chevron Havoline Extended Life Coolant XLC+B Valvoline Zerex G 30



### ATTENTION

Different types of coolant should not be mixed.  
Use only approved coolants for refill. The mixture  
of different types of coolant can cause severe  
damage to the engine.



### ATTENTION

Coolant additives protect not only against frost,  
but also against corrosion and amongst other  
things. Therefore, the coolant will be filled in the  
specified mixture ratio the whole year round. The  
mixture ratio may not be reduced by refilling.



### **3.4 Running in the engine**

Weber Automotive GmbH recommends that during the first five hours of operation, you should not operate the engine over 6,000 U/min [RPM]. This protective running-in has a positive effect on the engine's lifespan.

### **3.5 Operating the engine without sea water**

If it is necessary to operate the engine longer than 30 seconds without sea water, the vehicle's rinsing equipment must be used.

See chapter **Flush sea water cooling circuit after driving**.



#### **ATTENTION**

The engine may only be operated at idle speed for a maximum of 30 seconds without sea water. Engine damage due to overheating.



## 4 Maintenance

The table in chapter **Maintenance intervals** provides the manufacturer's recommended intervals for maintenance work. If you follow the maintenance recommendations, a long lifespan of the engine can be achieved and unnecessary environmental damage prevented. The Maintenance intervals specified in the table should not be exceeded by more than 10%.

If not stated otherwise, all activities on the engine described in this manual must be carried out by trained service personnel.

During the warranty period, maintenance and repair work may only be carried out in Weber Motor service stations or in associated shops. If necessary, contact your vehicle dealer.

Weber Automotive GmbH reserves the right to demand that proof of warranty be provided in writing for warranty service. See **Proof of maintenance for work carried out**.



### ATTENTION

The vehicle owner or user is responsible for adhering to the maintenance intervals. Weber Automotive GmbH assumes no liability for damage that arises due to maintenance not carried out.



## 4.1 Maintenance work by the user of the vehicle

### Regular checks before driving

Always check the oil level and coolant level before driving.

See Chapter **Oil level check**.

See Chapter **Coolant level check**.



**ATTENTION**

Underrunning and exceeding the motor oil and coolant fill levels specified in this manual can cause damage to the engine.

### Flush sea water cooling circuit after driving

In order to protect the sea water cooling circuit against soiling, calcium deposits and such, the sea water cooling circuit must be flushed after each use.



**ATTENTION**

Soiling in the sea water cooling circuit can cause severe damage to the exhaust manifold.

The flushing is done with a flush kit in the vehicle. See the vehicle manufacturer's service manual.

1. Connect the Flush kit.
2. Start engine and operate only in idle. Do not accelerate.
3. Ensure the water supply within 30 seconds. See Chapter Operating the engine without sea water.
4. The Weber Automotive GmbH recommends to flush the sea water cooling circuit for one minute minimum.
5. Discontinue water supply.
6. Stop engine within 30 seconds.
7. Remove the flush kit.



**ATTENTION**

Only flush engine while running, otherwise water from the exhaust can enter engine and cause damage.



## 4.2 Maintenance intervals

Activities on the engine must be carried out by trained service personnel.

Activity	Procedure	see page	1st maintenance h <sup>1)</sup>	Maintenance interval h <sup>1)</sup>		At end of season <sup>5)</sup>
			after 25	every 50	every 100	
Motor oil and oil filter	Change	14	■ <sup>2)</sup>	■ <sup>2)</sup>		■
Coolant	Change	20	■ every 4 years <sup>4)</sup>			
Spark plugs	Check / clean	23				■
	Change	23			■ <sup>3)</sup>	
Valve play	Check / set	26	■ <sup>3)</sup>		■ <sup>3)</sup>	

<sup>1)</sup> h = hours of operation

<sup>2)</sup> or at least once a year if the hours of operation specified above are not reached before that.

<sup>3)</sup> or at least every two years if the hours of operation specified above are not reached before that.

<sup>4)</sup> Valid for engine manufacturer's fill. Please note the instructions provided by coolant manufacturer, when using other coolants.

<sup>5)</sup> See chapter Decommissioning at the end of the season.



### **4.3 Decommissioning at the end of the season**

The decommissioning of the vehicle is necessary ...

... at the end of the season if the vehicle will be decommissioned during the winter months.

... if the vehicle will not be used for more than 30 days.

In addition to the maintenance work described in the maintenance interval table under **end of the season**, various other service work is also required.

#### **- Conserve the cylinders**

Check spark plugs. See Chapter **Checking the spark plugs**.

Fill approx. 10 ml [0.34 oz (US)] of clean motor oil directly through the spark plug holes. Before you replace the spark plugs, crank up the motor briefly with the starter. Replace the spark plugs.



#### **ATTENTION**

Never fill more motor oil than specified into the spark plug holes. Too much motor oil can cause engine damage.

#### **- Fill the fuel tank all the way**

A full fuel tank prevents the formation of condensation inside the tank.

#### **- Add fuel stabilizer**

After approx. 30 days, fuel begins to decompose. You can use any common fuel stabilizer in order to maintain the fuel quality.



## 4.4 Motor oil and oil filter

### Oil level check



- Use a clean, lint-free cloth



The oil level must be measured with oil warm from operation (approx. 80 °C [176 °F]) and with the motor at a standstill. Measurements with cold oil are not meaningful. The desired motor temperature is achieved after a driving time of approx. 10 minutes at 4000 - 4500 U/min [RPM].

Measurement with a motor warm from operation is necessary, because the oil volume changes depending on the temperature. To avoid mistaken measurements, the vehicle must be level.

If the motor is operated for a longer time under extreme conditions, the oil level may reach the MAX marking.

Oil level check (continuation)

- 1) Unscrew the oil dipstick (1) from the oil tank and wipe it clean with a cloth.
- 2) Replace the oil dipstick in the oil tank. **Do not screw it in.** Then remove it again and read the oil level.

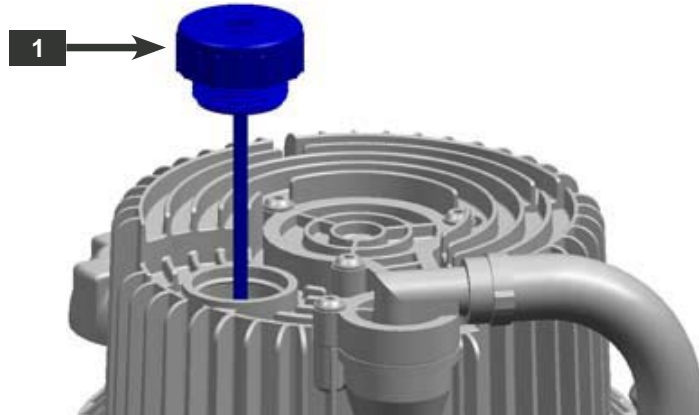

With a motor warm from operation, the oil level must be just below the MAX marking.

The difference between MIN and MAX is approx. 0.5 liter [0.53 qt (US)].

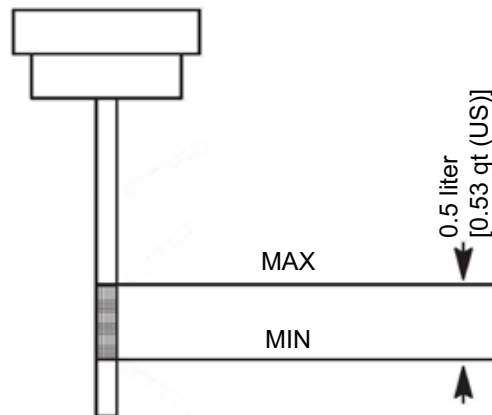

Underrunning the MIN marking and exceeding the MAX marking can cause severe and, under some circumstances, irreparable damage to the engine.

## Changing the motor oil and oil filter



- Oil extraction pump
- Catch basin for old oil, fill volume at least 4 liters [4.3 qt (US)]
- Flathead screwdriver or wrench to open the screw clamps
- Torque wrench to close the screw clamps
- Torque wrench SW27 [1 1/16 ""] for oil filter cover
- Possible hose extension for oil feed hose with screw clamps
- Funnel tube for motor oil



- Motor oil, see chapter Operating materials
- Oil filter, see spare parts catalogue

## Draining the motor oil



With a motor warm from operation, the greatest oil volume is sucked out of the motor.

- 1) Unscrew the oil dipstick from the oil tank.

See Chapter **Oil level check**.

- 2) Insert the suction hose of the oil extraction pump into the oil tank through an opening in the cover (1) until it reaches the bottom of the oil tank. X = 260 mm [10.25 in.].
- 3) Pump all the motor oil out.
- 4) Remove the suction hose and insert the oil dipstick again.

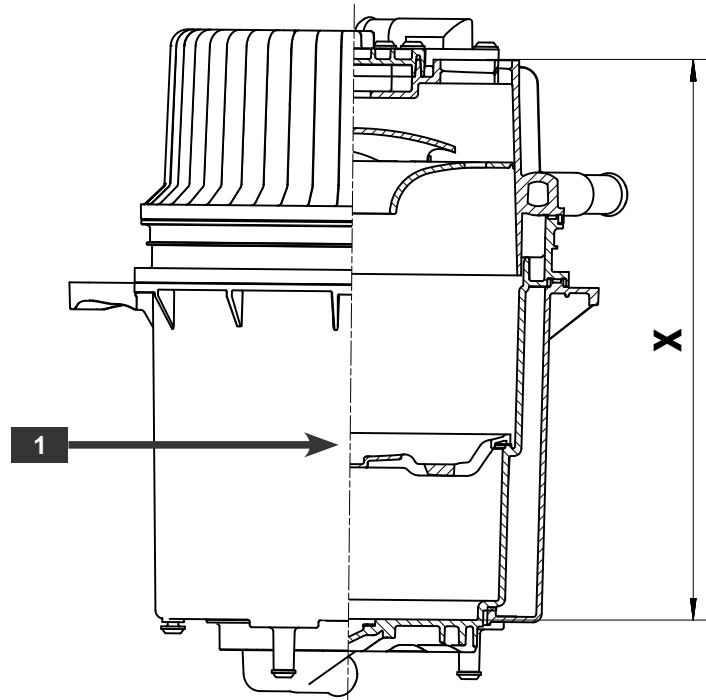

## Draining the motor oil (continuation)



The motor oil in the dry sump tank is pumped out with the help of the engine dry sump pump.

- 5) Remove the cable harness from the spark plugs and the injection valves. See Chapter **Removing the spark plugs**.
- 6) Remove the oil feed hose (2) on one side of the oil tank. If necessary, extend the oil feed hose.

→ Tightening torque:  
3 Nm ± 10 % [2.2 ft. lb.]

- 7) Activate the engine's starter every 10 seconds in order to let the engine crank and wait 30 seconds.
- 8) Repeat this procedure until the motor oil is pumped completely out.

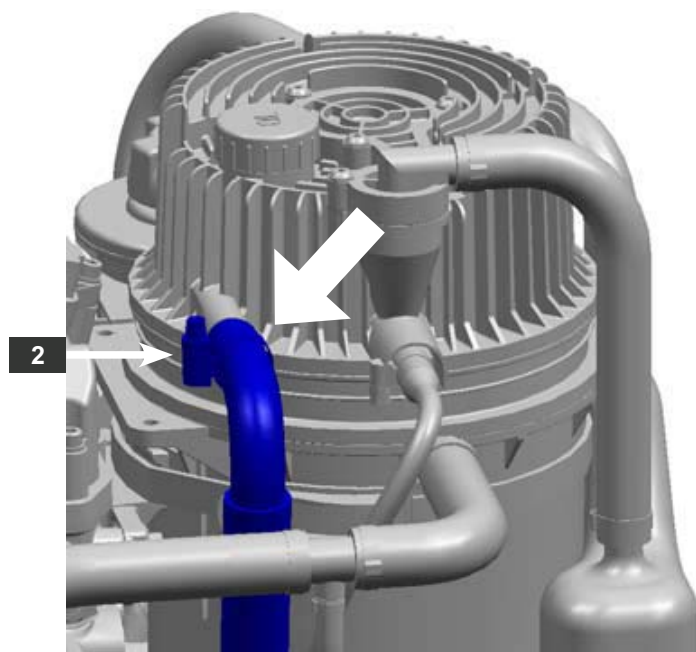

**ATTENTION**

Do not let engine crank longer than necessary to prevent damage due to insufficient lubrication and overloading of the starter.

Changing the oil filter

9) Unscrew the oil filter cover (3).

→ Tightening torque:  
24 Nm ± 10 % [17.7 ft. lb.]

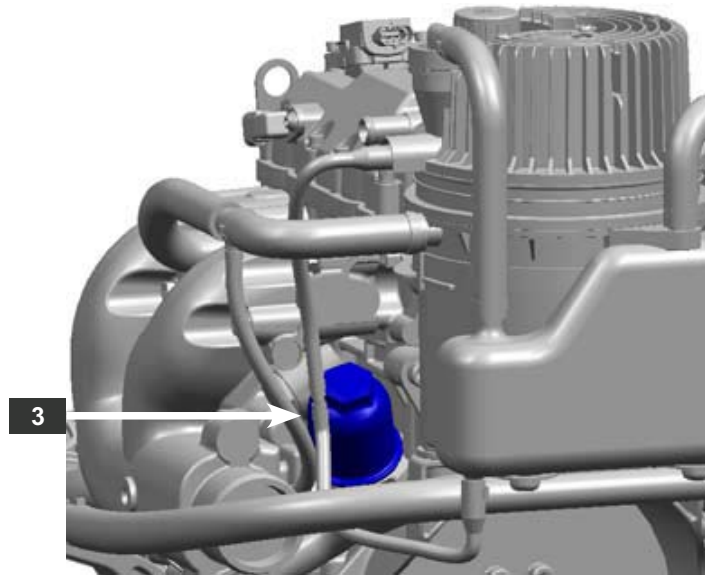

10) Replace the oil filter (4) and O-ring (5).

11) Coat the O-ring (5) lightly with motor oil.

→ During reassembly, make sure that the oil filter snaps in.

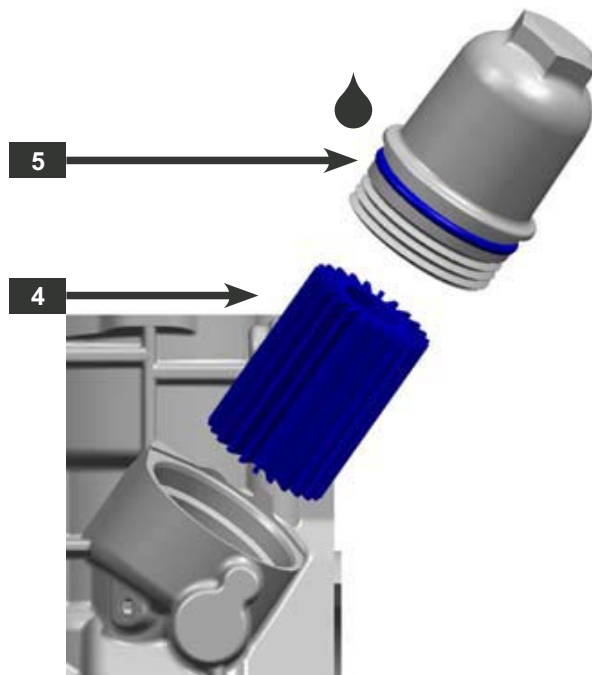

Assembly occurs in reverse order. Please note instructions after this symbol →



### Refilling the motor oil

- 12) Fill oil tank with 2.5 liters of motor oil.
- 13) Close the oil tank with the oil dipstick.
- 14) Warm up the motor in a body of water for approx. 10 minutes at 4000 - 4500 U/min.
- 15) Fill up the oil level with a motor warm from operation until just below the MAX marking.

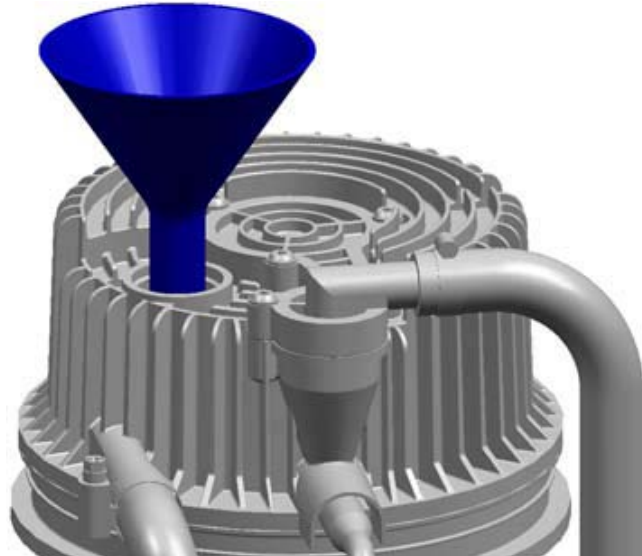

## 4.5 Engine cooling circuit

### Coolant level check

- Check the coolant level with a cold engine.  
With a cold engine, the coolant level should be between the MIN and MAX markings (1) of the compensation tank.
- If you must refill the coolant, see Chapter **Refilling the coolant**.

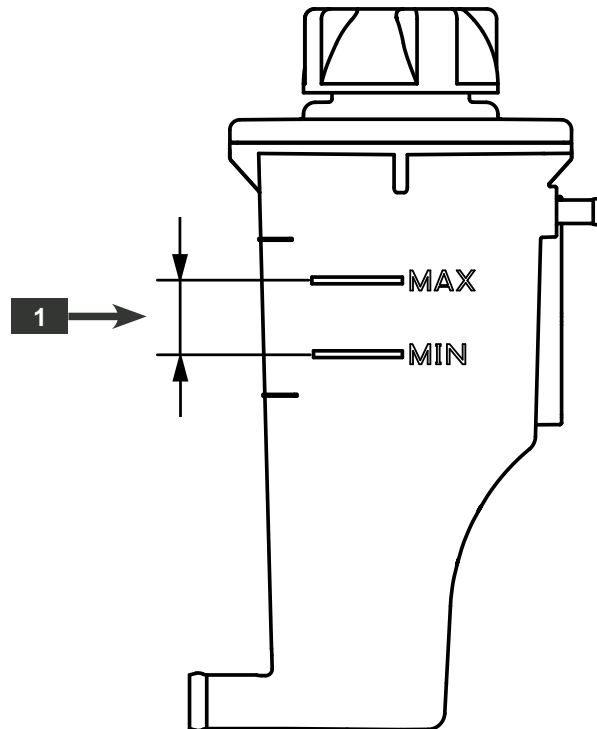
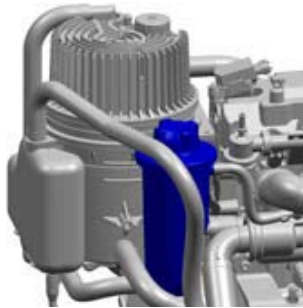

**ATTENTION**

Underrunning the MIN marking can cause damage to the engine due to overheating.

Exceeding the MAX marking should be avoided to prevent environmental damage.

## Changing the coolant



- Catch basin for the coolant, fill volume at least 4 liters [4.3 qt (US)]
- Flathead screwdriver or wrench to open the screw clamps
- Torque wrench to close the screw clamps
- Funnel tube for coolant



- Coolant, see chapter Operating materials

## Draining the coolant

- 1) Open the cover of the compensation tank (1).

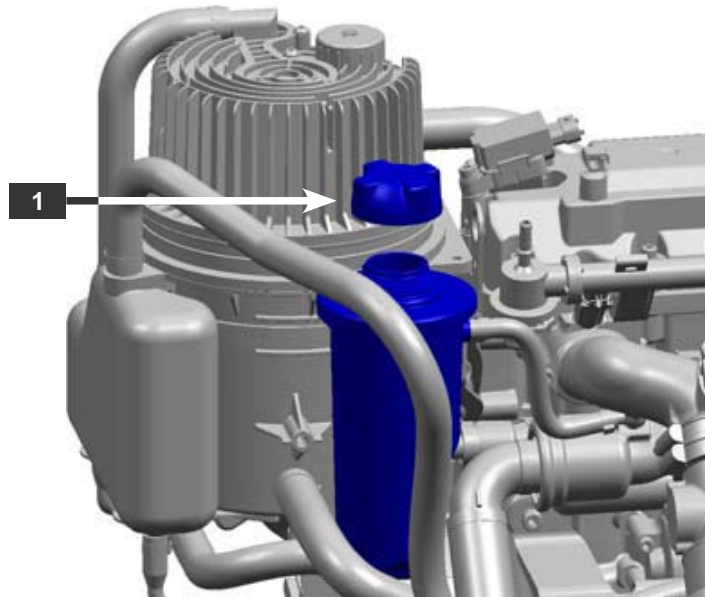

### WARNING

With a warm engine, remove the cover of the compensation tank slowly and release the excess pressure. Danger of burning unprotected hands.



### Draining the coolant (continuation)

- 2) Remove the screw clamps, hoses (2) on both sides and drain coolant.

- ➔ Tightening torque:  
3 Nm ± 10 % [2.2 ft. lb.]
- ➔ Tighten the screw clamps after one to three hours.

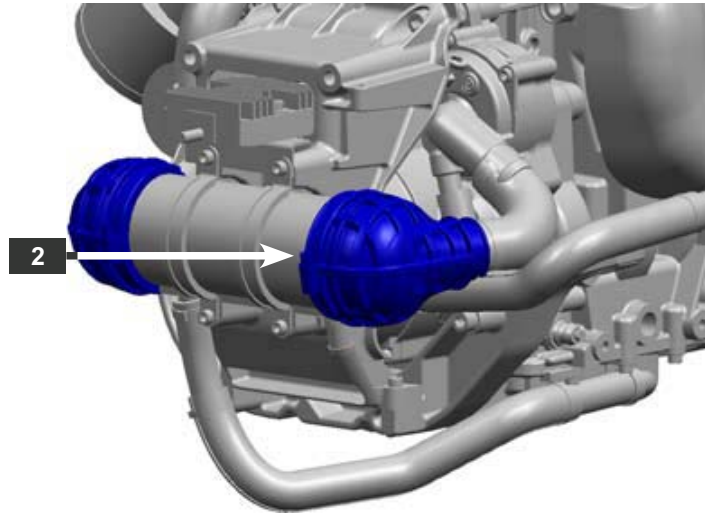

Assembly occurs in reverse order. Please note instructions after this symbol ➔

## Refilling the coolant

- 3) Open the cover of the compensation tank. See Chapter **Draining the coolant**.
- 4) Add new coolant up to the MAX marking of the compensation tank. See Chapter **Coolant level check**.
- 5) Close the cover of the compensation tank.
- 6) Start the engine briefly and fill the compensation tank up to the MAX marking. See Chapter **Operating the engine without sea water**.
- 7) The vehicle can now be put into operation as usual. After running for 5 minutes, check the coolant level again and, if necessary, fill up to the MAX marking.

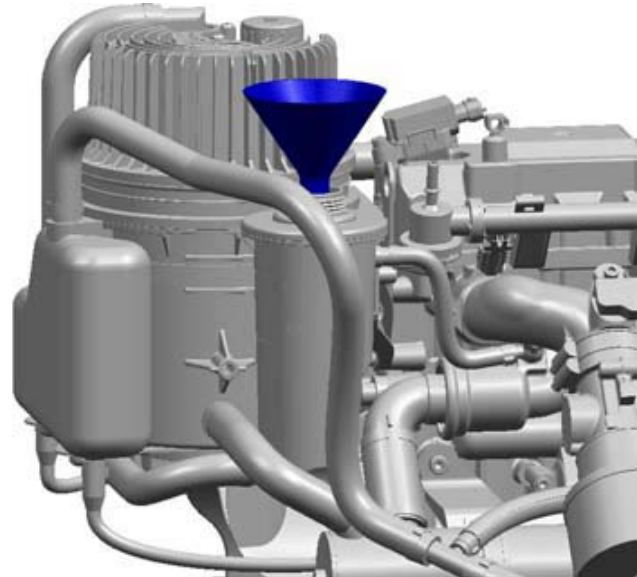

### **WARNING**

Do not fill coolant while the engine is running, and with a warm engine, remove the cover of the compensation tank slowly and release the excess pressure. Danger of burning unprotected hands.

## 4.6 Spark plugs

### Checking the spark plugs



- Socket wrench SW16 [5/8 "]
- Feeler gauge, measurement range 0.77 mm - 0.91 mm [0.0303 - 0.0358 in.]
- Torque wrench



- 2x spark plugs, see spare parts catalogue

### Removing the spark plugs

- 1) Remove cable harness on the ignition coils (1).
- 2) Remove the cable harness on the injection valves (2).

➔ Before disassembling, make sure that the plugs of the ignition coils and the injection valves are not switched during assembly.

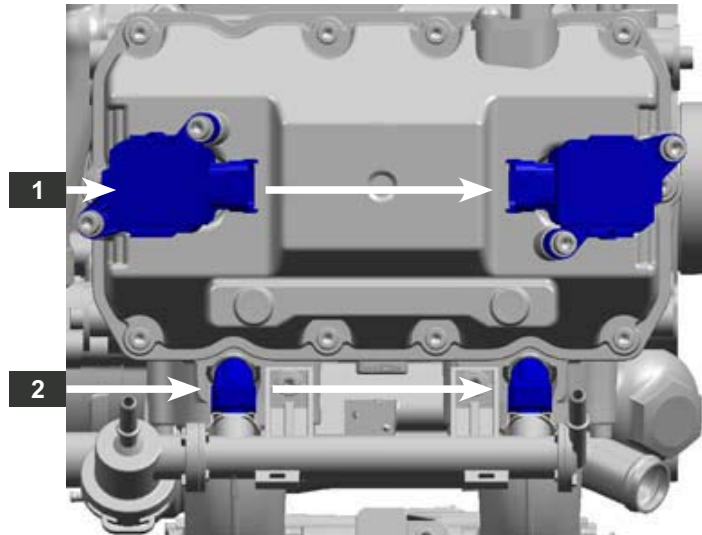



**Removing the spark plugs (continuation)**

- 3) Remove the screws and washers (3).
- 4) Remove the ignition coils (4)

➔ Install the spark plugs only in a cold engine.

➔ Grease the threads of the spark plugs with commercial graphite grease.

➔ Tightening torque:  
10 Nm ± 10 % [7.4 ft. lb.]

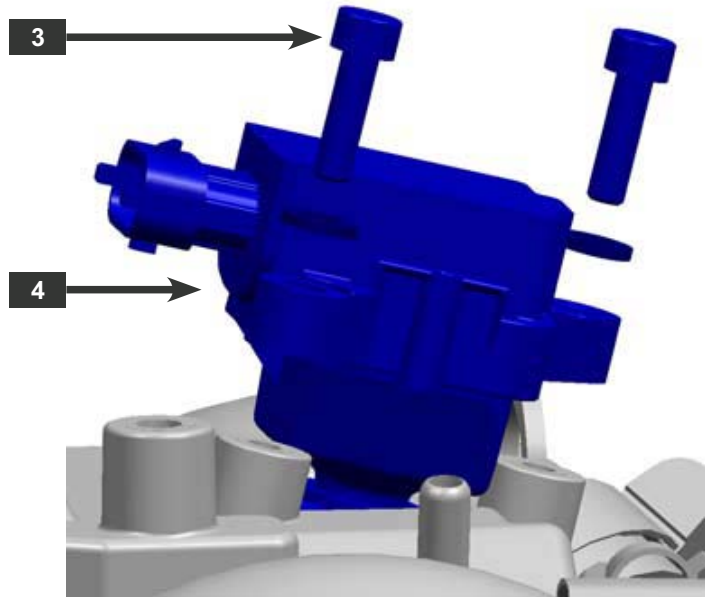

- 5) Unscrew the spark plugs (5).

➔ Tightening torque:  
27 Nm ± 20 % [19.9 ft. lb.]

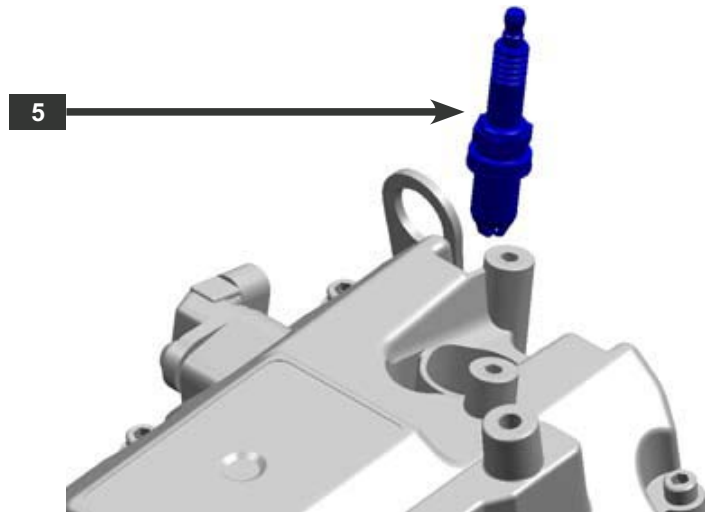

Assembly occurs in reverse order. Please note instructions after this symbol ➔ as well as consulting the vehicle manufacturer's service manual.



**Checking the spark plugs**

- 6) Check the electrode distance of the spark plugs with the help of the feeler gauge.

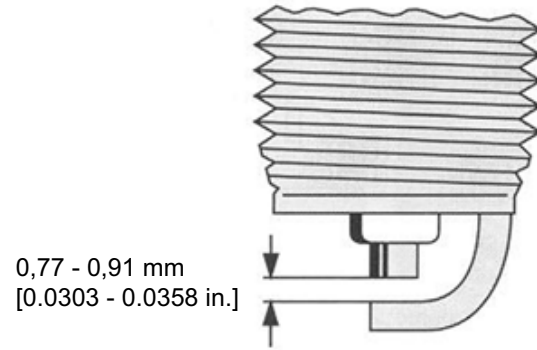

## 4.7 Valve play

### Checking and setting the valve play



- Hex wrench SW5 [3/16 "]
- Feeler gauge, measurement range 0.08 mm - 0.25 mm [0.0031 - 0.0098 in.]
- Valve adjustment tool, see spare parts catalogue
- Combination wrench 24mm [15/16 "]
- Bar magnet
- Measurement tool for adjustment plate, reading 0.01mm [0.0003 in.]



- Adjustment plates from 2.5 - 3.7 mm [0.0984 - 0.1457 in.], see spare parts catalogue
- Valve cover seals, see spare parts catalogue
- 2x O-rings, see spare parts catalogue



To get correct measurement valves, check and adjust valve play with a cold engine.

### Removing the valve cover

- 1) Remove the cable harness on the cam shaft sensor (1).
- 2) Remove the spark plugs.  
See Chapter **Removing the spark plugs**.

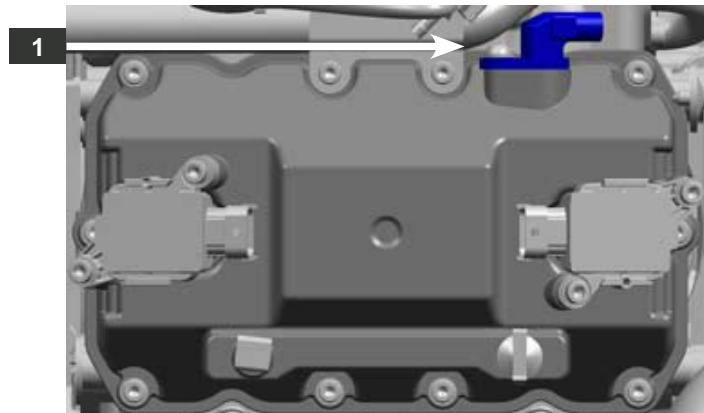



Removing the valve cover (continuation)

- 3) Unscrew the valve cover (2) along with bracket and valve (3).

→ Tightening torque:  
10 Nm ± 10 % [7.4 ft. lb.]

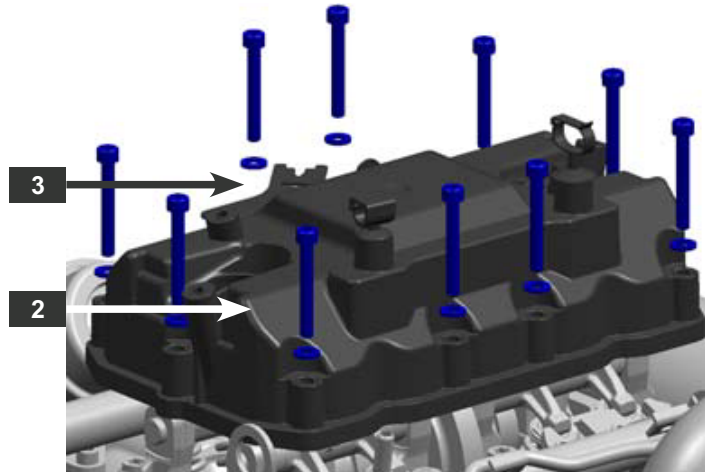

→ The sequence of the connection occurs according figure.



- Replace the valve cover seals (4).
- Clean seal areas of the valve cover and cylinder head.

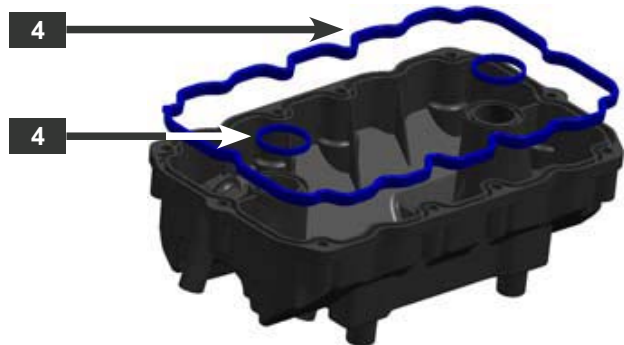

Assembly occurs in reverse order. Please note instructions after this symbol →

Checking the valve play of the first cylinder

- 4) Start the vehicle's starter and let the engine crank until both cams of the second cylinder are pointing upwards.

The rocker of the first cylinder demonstrates a little play.

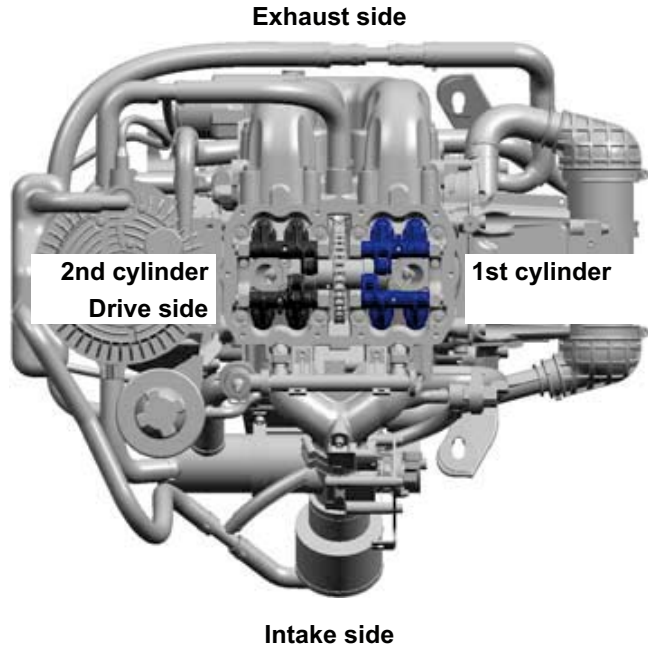
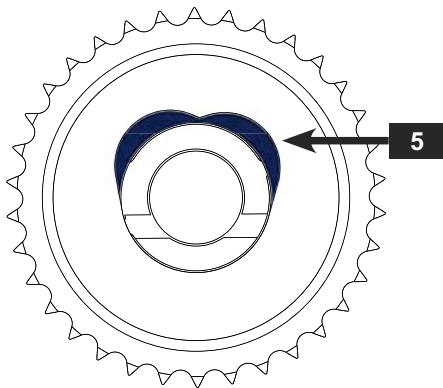

- 5) Using a feeler gauge, measure the valve play (6) of all four valves of the first cylinder between the adjustment plates and the rockers.

Permissible valve play:

**Intake side**

**0,08 - 0,15 mm**  
**[0.0031 - 0.0059 in.]**

**Exhaust side**

**0,15 - 0,22 mm**  
**[0.0059 - 0.0087 in.]**

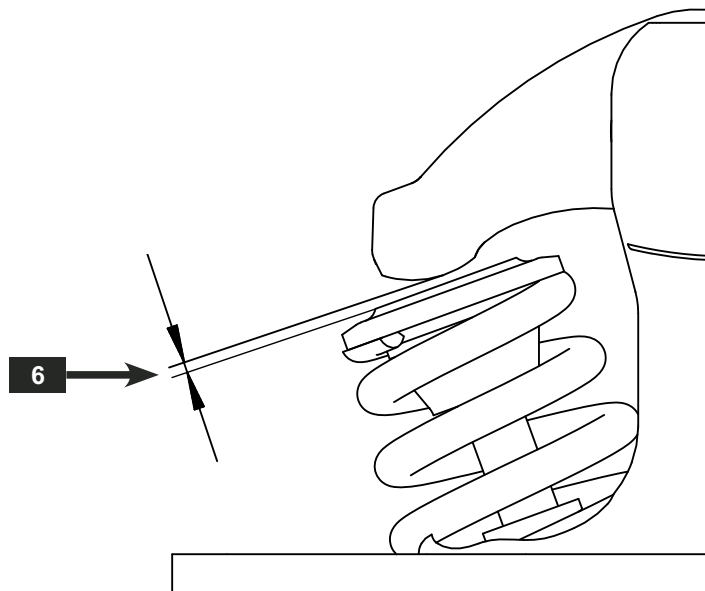

**Adjusting the valve play**

- 6) To adjust the valve play on the intake side, it is necessary to remove the fuel distributor rail. Remove the cable harness on the coolant sensor (7).

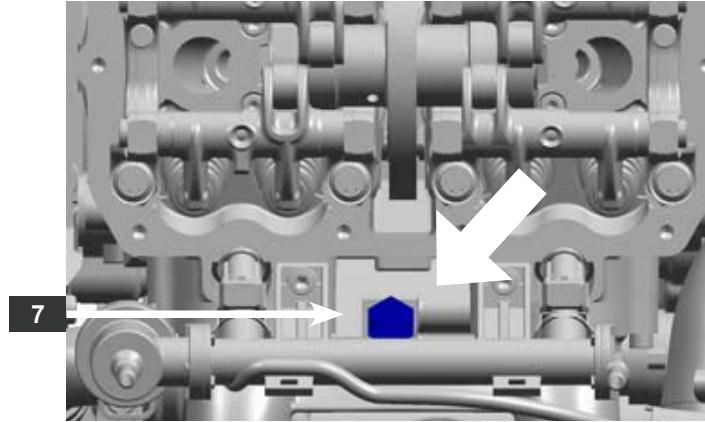

- 7) Loosen the screws and washers (8) and remove the fuel distributor rail (9).

➔ Tightening torque:  
10 Nm ± 10 % [7.4 ft. lb.]

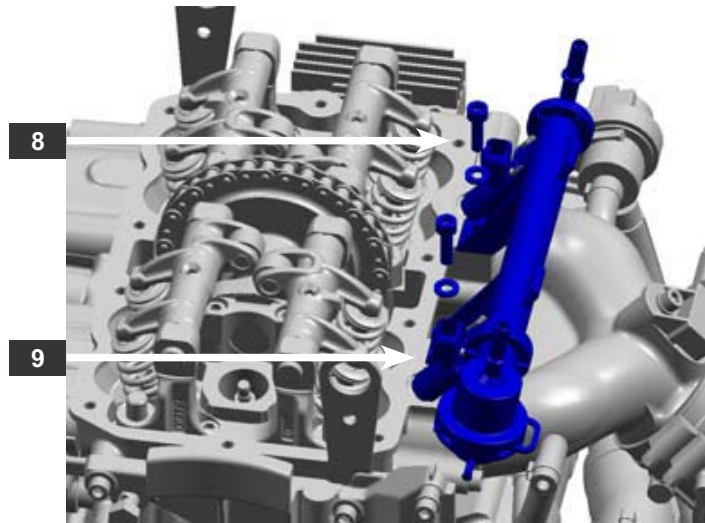

Adjusting the valve play (continuation)

➔ Replace the O-rings (9) on the injector valves. Coat the O-rings lightly with motor oil.

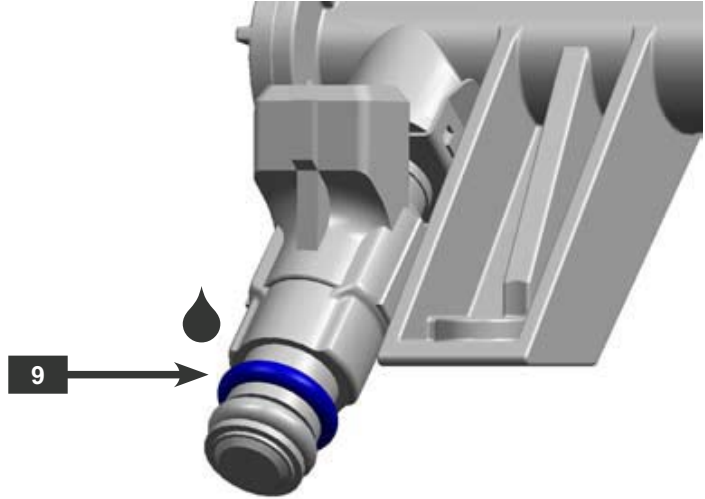

8) Mount the valve adjustment tool (11) with two screws.  
Tightening torque:  
10 Nm ± 10 % [7.4 ft. lb.]

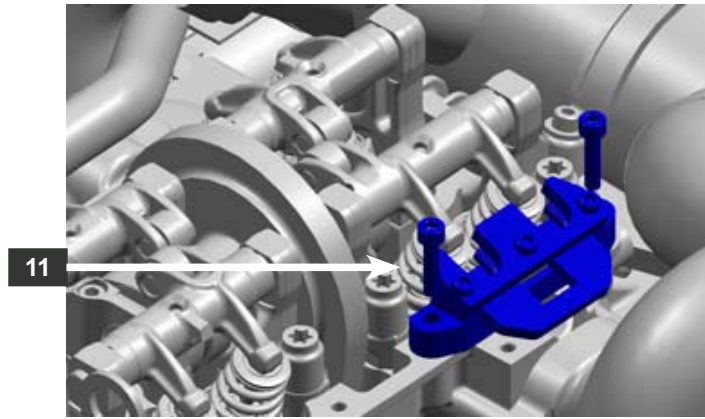

The engine may not be turned over until all valve plays of the first cylinder are adjusted.

### Adjusting the valve play (continuation)

- 9) Press the rocker downwards with a 24 combination wrench (12).
- 10) Clamp both valves by pressing in the sliding piece (13).
- 11) Remove the adjustment plate with the bar magnet.
- 12) Measure the strength of the adjustment plate and replace with an adjustment plate with which the permissible tolerance is adhered to.
- 13) Replace the adjustment plate in the spring seat.
- 14) Remove the sliding piece (13) and, to check the valve play, measure again.
- 15) Repeat this procedure with all valves of the first cylinder.



### Checking the valve play of the second cylinder

- 16) Start the vehicle's starter and let the engine crank until both cams of the first cylinder are pointing upwards.  
The rocker of the second cylinder demonstrates a little play.
- 17) Check the valve play of the second cylinder in the same way you did the first cylinder.

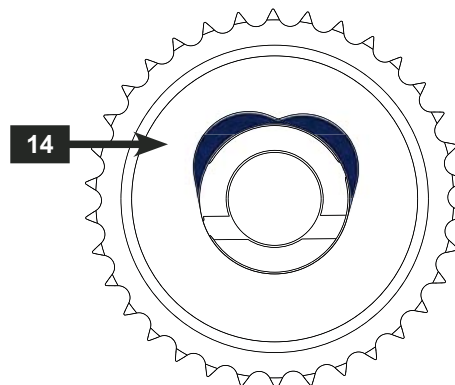

## 5 Malfunctions

If you cannot correct a malfunction yourself using the table below, contact your vehicle dealer's customer service.

In case of improperly-made repairs, the warranty is voided and Weber Automotive GmbH is not liable for any resulting subsequent damage.

### Engine does not crank

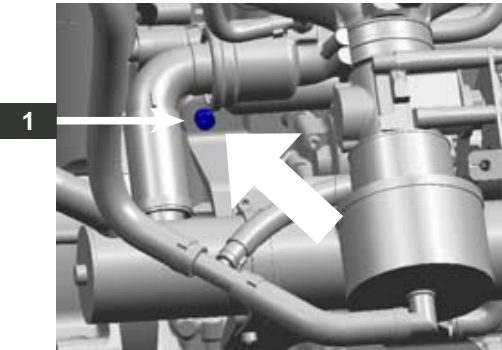
Possible cause	Remedy
Main power switch not plugged in.	Plug in main power switch.
Battery voltage too low. - Open-circuit voltage < 12 volts. - During activation of the starter < 10.5 volts.	Remove soiling and corrosion on the battery poles and connect battery connections correctly.  With non maintenance-free batteries, check water level.  Charge battery with external battery charger
Engine mass point (1) not connected or not connected properly.	Check connection.
	
Defective fuse.	Check the fuses in the cable harness.
Drive or jet pump blocked.	Remove blockage.
Cable harness plug connections not plugged in or not plugged in correctly.	Check plug connections.



### Engine cranks but does not start

Possible cause	Remedy
Lanyard not plugged in.	Plug in lanyard.
Defective fuse.	Check the fuses in the cable harness.
Too little or no fuel in the tank.	Fill up fuel.  Check the engine for signs of leaky fuel lines and, if necessary, have it checked by a professional shop.
Cable harness plug connections not plugged in or not plugged in correctly.	Check plug connections.
Spark plugs defective.	Check the spark plugs and, if necessary, replace them. See Chapter <b>Spark plugs</b> .

### Engine stalls but can be started again

Possible cause	Remedy
Too little or no fuel in the tank.	Fill up fuel.  Check the engine for signs of leaky fuel lines and, if necessary, have it checked by a professional shop.
Too much motor oil.	Check the oil level.  See Chapter <b>Oil level check</b> .  Excessive motor oil must be pumped out as quickly as possible.



**Engine stalls and cannot be started again**

<b>Possible cause</b>	<b>Remedy</b>
Lanyard not plugged in.	Plug in lanyard.
Defective fuse.	Check the fuses in the cable harness.
Too little or no fuel in the tank.	Fill up fuel.  Check the engine for signs of leaky fuel lines and, if necessary, have it checked by a professional shop.
Cable harness plug connections not plugged in or not plugged in correctly.	Check plug connections.
Spark plugs defective.	Check the spark plugs and, if necessary, replace them. See Chapter <b>Spark plugs</b> .

**Engine loses power (speed limitations)**

<b>Fault</b>	<b>Possible cause</b>	<b>Remedy</b>
Engine speed limited to 1800 U/Min [RPM] and the water temperature warning lamp lights up.	Overheating of exhaust manifold.	DO NOT LET THE ENGINE RUN LONGER THAN 30 SECONDS. Rinse and check the sea water cooling circuit. See Chapter <b>Flush sea water cooling circuit after driving</b> . Check the sea water pump.



## **6 Terminology**

### **A**

---

Adjusting the valve play 28

### **C**

---

Changing the coolant 19

Changing the oil filter 16

Checking the spark plugs 24

Checking the valve play 27

Coolant 6

Coolant level check 18

### **D**

---

Decommissioning at the end of the  
season 11

Draining the coolant 19

Draining the motor oil 14

### **F**

---

Flush sea water cooling circuit after  
driving 9

Fuel 5

### **L**

---

Lubricant 5

### **M**

---

Maintenance intervals 10

Maintenance work by the user of the  
vehicle 9

Malfunctions 31

### **O**

---

Oil level check 12

Operating materials 5

Operating the engine without sea water  
7

### **R**

---

Refilling the coolant 21

Refilling the motor oil 17

Regular checks before driving 9

Removing the spark plugs 22

Removing the valve cover 25

Running in the engine 7

### **S**

---

Serial number 4

Submerged engine 3

### **T**

---

Technical specifications 4



## 7 Appendix

<b>Manufacturer</b>	Weber Automotive GmbH	
<b>Address</b>	Otto-Lilienthal-Str.5 88677 Markdorf Germany	
<b>Internet</b>	<a href="http://www.weber-automotive.com">www.weber-automotive.com</a>	
<b>Engine</b>	I2 749 MAR NA-66 DS V1 2007 1.1	
<b>Engine family</b>	WEBM.750NG	(EU family designation)
	8WEBM.7508NG	(USA family designation, adjusted to the model year annually)

### 7.1 Directives

Weber Automotive GmbH thus confirms that the construction of the engine corresponds to the following pertinent conditions:

- EU directive about sport boats 94/25/EG with addendum 2003/44/EG
- USA EPA Federal Register 40 CFR Part 91
- USA CARB 13 California Code of Regulation Article 4.7 Spark Ignition Marine Engines



## **7.2 Exhaust type authorizations**

**Type test center Europe**      Germanischer Lloyd

**Type test center USA**      EPA (United States Environmental Protection Agency)

The output of the motor is 49 kW.

---

All originals are present and can be viewed at any time.

They can be called up on the Internet at [www.weber-automotive.com](http://www.weber-automotive.com).

---

Appendices to this service manual:

„Declaration of Conformity for Recreational Craft Propulsion Engines“

„California Emission Control Warranty Statement“





Date:	<b>Work carried out:</b> <input type="checkbox"/> Motor oil change <input type="checkbox"/> Oil filter change <input type="checkbox"/> Spark plug change <input type="checkbox"/> Valve play checked <input type="checkbox"/> Valve play adjusted <input type="checkbox"/> Coolant change
Status	..... ..... ..... ..... .....
Hours of operation:	..... ..... ..... ..... .....
Company seal, signature	.....

Date:	<b>Work carried out:</b> <input type="checkbox"/> Motor oil change <input type="checkbox"/> Oil filter change <input type="checkbox"/> Spark plug change <input type="checkbox"/> Valve play checked <input type="checkbox"/> Valve play adjusted <input type="checkbox"/> Coolant change
Status	..... ..... ..... ..... .....
Hours of operation:	..... ..... ..... ..... .....
Company seal, signature	.....

Date:	<b>Work carried out:</b> <input type="checkbox"/> Motor oil change <input type="checkbox"/> Oil filter change <input type="checkbox"/> Spark plug change <input type="checkbox"/> Valve play checked <input type="checkbox"/> Valve play adjusted <input type="checkbox"/> Coolant change
Status	..... ..... ..... ..... .....
Hours of operation:	..... ..... ..... ..... .....
Company seal, signature	.....

Date:	<b>Work carried out:</b> <input type="checkbox"/> Motor oil change <input type="checkbox"/> Oil filter change <input type="checkbox"/> Spark plug change <input type="checkbox"/> Valve play checked <input type="checkbox"/> Valve play adjusted <input type="checkbox"/> Coolant change
Status	..... ..... ..... ..... .....
Hours of operation:	..... ..... ..... ..... .....
Company seal, signature	.....

Date:	<b>Work carried out:</b> <input type="checkbox"/> Motor oil change <input type="checkbox"/> Oil filter change <input type="checkbox"/> Spark plug change <input type="checkbox"/> Valve play checked <input type="checkbox"/> Valve play adjusted <input type="checkbox"/> Coolant change
Status	..... ..... ..... ..... .....
Hours of operation:	..... ..... ..... ..... .....
Company seal, signature	.....

Date:	<b>Work carried out:</b> <input type="checkbox"/> Motor oil change <input type="checkbox"/> Oil filter change <input type="checkbox"/> Spark plug change <input type="checkbox"/> Valve play checked <input type="checkbox"/> Valve play adjusted <input type="checkbox"/> Coolant change
Status	..... ..... ..... ..... .....
Hours of operation:	..... ..... ..... ..... .....
Company seal, signature	.....

Date:	<b>Work carried out:</b> <input type="checkbox"/> Motor oil change <input type="checkbox"/> Oil filter change <input type="checkbox"/> Spark plug change <input type="checkbox"/> Valve play checked <input type="checkbox"/> Valve play adjusted <input type="checkbox"/> Coolant change
Status	..... ..... ..... ..... .....
Hours of operation:	..... ..... ..... ..... .....
Company seal, signature	.....

Date:	<b>Work carried out:</b> <input type="checkbox"/> Motor oil change <input type="checkbox"/> Oil filter change <input type="checkbox"/> Spark plug change <input type="checkbox"/> Valve play checked <input type="checkbox"/> Valve play adjusted <input type="checkbox"/> Coolant change
Status	..... ..... ..... ..... .....
Hours of operation:	..... ..... ..... ..... .....
Company seal, signature	.....